

SERIES SKID
STEER LOADER



SWL2820 All-powerful small machines with big helpers

◆ Operating weight: 2830kg ◆ Rated operating capacity : 750kg



- ◆ Strong power, high reliability, low noise, energy saving, and environmental protection.
- ◆ Independent research and development of arc lifting mechanism, simple structure, strong bearing capacity, good reliability.
- ◆ ISO pilot operating mode with easy operation, flexible control and good inching performance.
- ◆ International universal quick-change device with easy switching of cleaning, milling, snow-blowing, and other accessories.
- ◆ Standard bucket floating and automatic leveling function that greatly improves the work efficiency.
- ◆ All-around maintenance space that ensures easy access to the parts to be maintained and facilitates maintenance.



Machine Dimensions			
Boundary dimension(L×W×H)		mm	3307X1600X2014
A	Maximum overall height	mm	3850
B	Height to hinge pin	mm	3002
C	Height to top of cab	mm	2014
D	Height to bottom of level bucket	mm	2834
E	Length without standard bucket	mm	2604
F	Length with bucket	mm	3307
G	Maximum dump angle	°	42
H	Dump height	mm	2320
J	Dump reach	mm	475
K	Rollback angle (bucket on ground)	°	30
L	Rollback angle at maximum height	°	97
M	Wheelbase (Track Gauge)	mm	996
P	Ground	mm	212
Q	Departure angle	°	25
R	Turning radius from center (Coupler)	mm	1235
S	Turning radius from center (Bucket)	mm	1953
T	Turning radius from center (Machine rear)	mm	1531
U	Bumper overhang behind rear axle	mm	1001
V	Width over tire(Crawler Base)	mm	1293
W	Bucket width	mm	1600

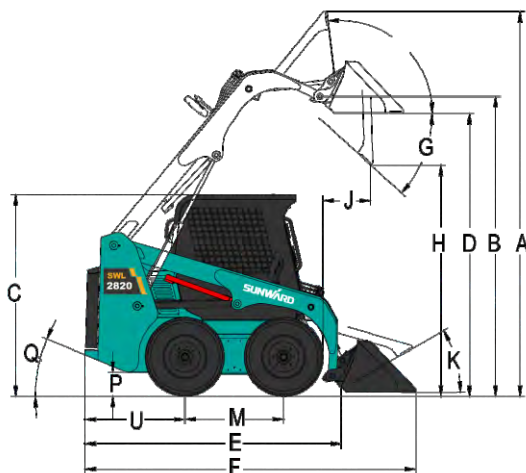

Performance			
Operating weight	kg	2830	
Rated operating capacity	kg	750	
Tipping load	kg	1500	
Breakout force curl	kg	2000	
Breakout force lift	kg	1900	
Travel speed	kph	13	
Engine			
Brand		KUBOTA	XINCHAI
Model		V2403-M-DI-E3B	4D29G31
Type		4-cylinder,water-cooled,diesel engine	
Emission level		EU stage III	GB III
Power	kW/rpm	36.0/2600	36.7/2500
Peak torque	N.m/rpm	156.3/1600	155/1700~1900
Transmission system			
Type		Hydrostatic closed circuit	
Pump		Variable displacement piston pump	
Motor		2XRadial plunger quantitative single speed motor	
Hydraulic system			
Type		Throttling system	
Bump		Gear pump	
Hydraulic flow_Standard Hydraulic flow_High flow	lpm	63/92	
Pressure	bar	210	
Control valve		Three joint multi-way valve	
Control mode		ISO model of pilot control	
Electric system			
Starter	V/kW	12/2.0	12/3.0
Alternator rating	V/A	12/60	14/53.5
Battery	Ah	120	
Service refill capacities			
Hydraulic tank	L	23	
Fuel tank	L	75	
Traveling system			
Tire		10-16.5	
Track		---	

